

**MODEL 742 HAY CONDITIONER
for 942 & 972 Headers
PARTS CATALOG**

CONTENTS

HAY CONDITIONER

FRAME, ROLLS & ROLL ARMS.....	2,3
L/H DRIVES	4,5
R/H DRIVES.....	6
ROLL GAP & TENSION GROUP	7
HEADER MOUNTING PARTS	8,9
FLOAT GROUP	10,11
FORMING SHIELD GROUP	12,13

NUMERICAL LIST.....	14
----------------------------	-----------

SUGGESTED STOCKING LIST.....	15
-------------------------------------	-----------

ABBREVIATIONS

L/H - left hand (Determined from Operator's position, facing forward.)

R/H - right hand

I.D. - inside diameter

O.D. - outside diameter

A/R - as required (quantity varies with header size)

REF - reference, part number called up elsewhere in catalog

SUB - Substitute (Revised design may be used to repair previous design when stock is depleted.)

NC - national coarse thread

NF - national fine thread

NOTE: Common hardware is not illustrated. Alphabetic references are used to designate position and description of these items.

When ordering, be sure the complete and proper serial number is given. Some parts vary with header size; be sure you are ordering the correct number for your header.

SERIAL NUMBER BREAKS

The side of the serial number on which the dash (-) appears determines whether the part is used "up to" or "after" the serial number given.

Example: -74924 Used on machines up to and including serial number 74924.

 74925- Used on machines including and after serial number 74925.

BOLDED PART NUMBERS INDICATE REVISIONS OR ADDITIONS SINCE LAST PRODUCTION YEAR.
--

742 Hay Conditioner FRAME, ROLLS & ROLL ARMS

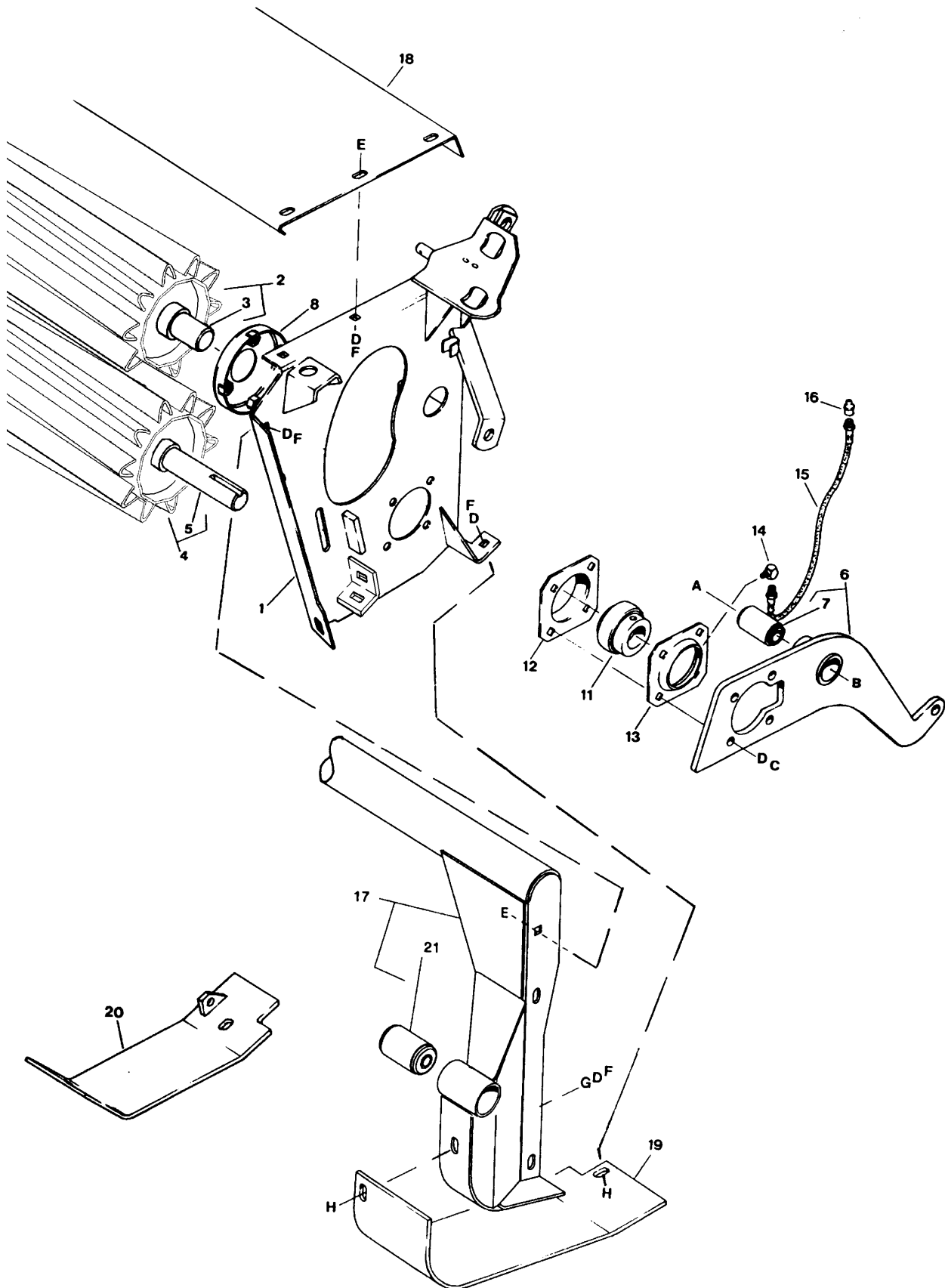

**742 Hay Conditioner
FRAME, ROLLS & ROLL ARMS**

REF	PART NUMBER	DESCRIPTION	QTY	SERIAL NUMBER
1	115976	PANEL - side, left	1	
	115977	PANEL - side, right	1	
2	125049	ROLL – upper (was 115776)	1	
3	47711	SHAFT - upper roll, left (welded)	1	
	47713	SHAFT - roll, right (welded)	1	
4	125050	ROLL – lower (was 115777)	1	
5	47712	SHAFT - lower roll, left (welded)	1	
	47713	SHAFT - roll, right (welded)	1	
6	115772	ARM - upper roll, with bushing	2	
7	30574	BUSHING - rubber	2	
8	101173	COVER - bearing	4	
11	30031	BEARING - with lock collar	4	
12	30576	FLANGE - bearing, inner	4	
13	50182	FLANGE - bearing, with lube hole (less fitting)	4	
14	50187	FITTING - adapter	4	
15	47723	HOSE - lube, except to top left bearing	3	
	47724	HOSE - lube, top left bearing	1	
16	50188	FITTING - lube	4	
17	115770	ADAPTER – front mounting, with 2 bushings (item 21)	1	
18	52040	COVER - top	1	
19	52102	SHOE - left	1	
20	52117	SHOE - right	1	
21	21897	BUSHING – rubber	2	
A	30906	BOLT - hex head, 3/4 NC x 7-1/2 inch (left roll arm)		
	30876	BOLT - hex head, 3/4 NC x 4 inch (right roll arm)		
B	18689	NUT - lock, 3/4 NC distorted thread		
C	18723	BOLT - hex head, 1/2 NC x 1-1/2 inch (upper roll)		
	21491	BOLT - hex head, 1/2 NC x 1-1/4 inch (lower roll)		
D	18638	WASHER - lock, 1/2 inch		
E	21868	BOLT - round head, short square neck, 1/2 NC x 1 inch		
F	18591	NUT - hex, 1/2 NC		
G	18599	WASHER - flat, 17/32 inch I.D.		
H	21471	BOLT - round head, square neck, 1/2 NC x 1-1/4 inch		

742 Hay Conditioner L/H DRIVES

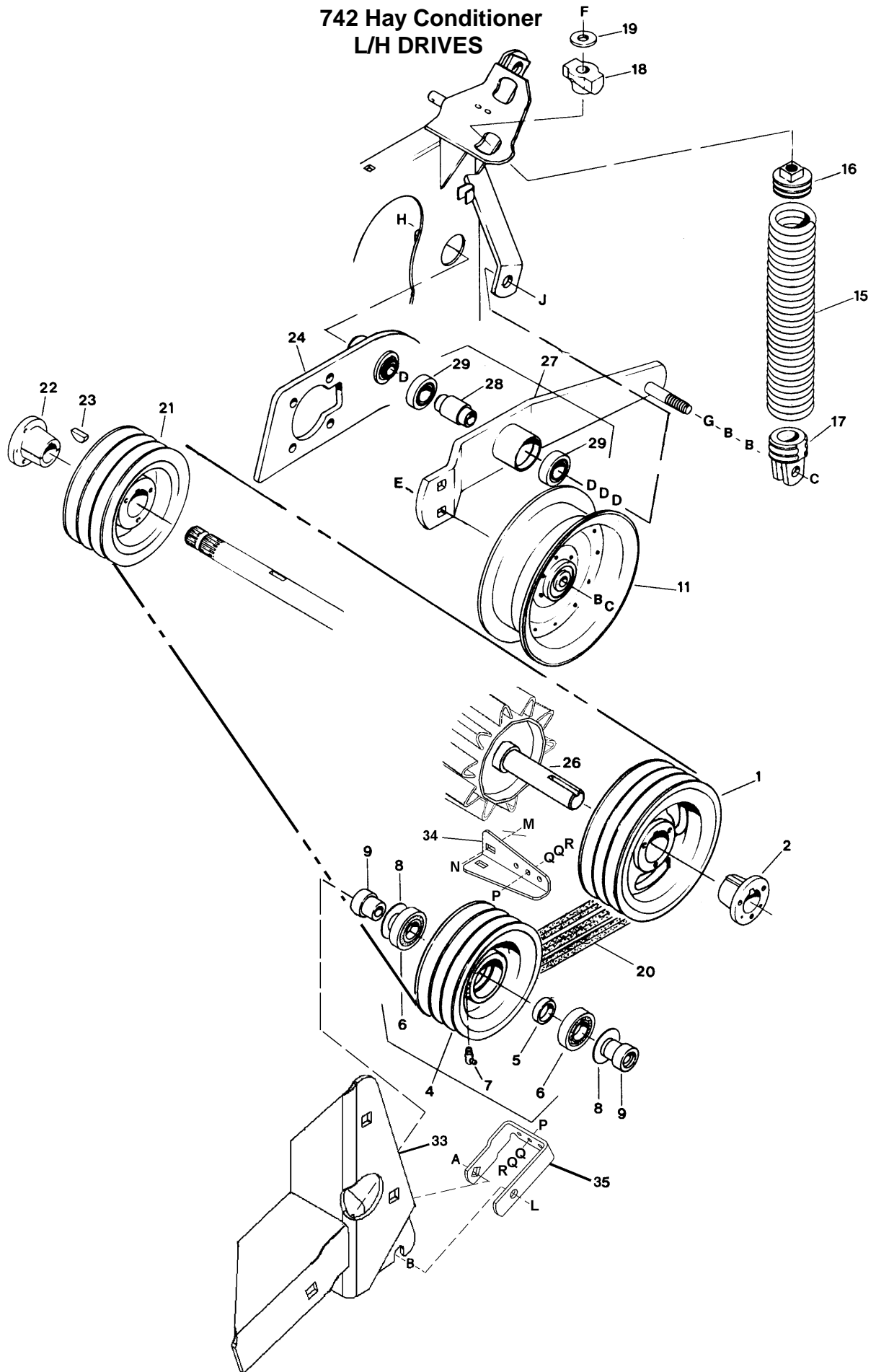

742 Hay Conditioner L/H DRIVES

REF	PART NUMBER	DESCRIPTION	QTY	SERIAL NUMBER
1	47972	PULLEY - driven, lower roll	1	
2	30256	BUSHING - split taper, with bolts & inner/outer key	1	
4	115890	PULLEY ASSEMBLY - idler, includes items 5, 6 & 7	1	
5	47976	SPACER - bearing.....	1	
6	30090	BEARING - ball.....	2	
7	21301	FITTING - lube, 45°	1	
8	47978	WASHER - flat	2	
9	47977	SPACER - stepped.....	2	
11	47966	PULLEY - flat idler	1	
15	47048	SPRING - idler tension	1	
16	47922	INSERT - spring, with threaded hole	1	
17	47925	INSERT - spring, with clevis	1	
18	36011	PIVOT - spring.....	1	
19	22072	WASHER - flat	1	
20	47994	BELT - matched set of three, use with 942 Multi-Crop Header.....	1	
	101110	BELT - matched set of three, use with 972 Harvest Header.....	1	
21	47969	PULLEY - driver, header drive shaft.....	1	
22	21934	BUSHING - split taper, with bolts & outer key	1	
23	11142	KEY - woodruff, 5/16 x 1 1/8 diameter	1	
24	REF	ARM - upper roll, see page 3		
25	REF	ADAPTER - front, see page 3		
26	REF	ROLL - lower, see page 3		
27	52159	ARM - idler, with spacer and bearings (items 28 & 29)	1	
28	52161	SPACER - machined.....	1	
29	21062	BEARING - ball.....	2	
33	REF	SUPPORT – left, see page 9	1	
34	115896	ANGLE – clean out bolt mounting, driven pulley	1	
35	115892	SUPPORT – clean out bolt mounting, idler pulley.....	1	
A	21162	BOLT - round head, square neck, 5/8 NC x 4-1/2 inch		
B	18600	WASHER - flat, 21/32 inch I.D.		
C	18666	NUT - lock, 5/8 NC distorted thread		
D	18601	WASHER - flat, 13/16 inch I.D.		
E	18525	BOLT - round head, square neck, 5/8 NC x 2-1/2 inch		
F	50190	BOLT - hex head, 5/8 NC x 7-1/2 inch, thread full length		
G	18593	NUT - hex, 3/4 NC (spacer)		
H	30906	BOLT - hex head, 3/4 NC x 7-1/2 inch		
J	18689	NUT - lock, 3/4 NC distorted thread		
K	21941	NUT - lock, jam 5/8 NC distorted thread		
L	50225	NUT – lock, smooth flange, 5/8 NC distorted thread		
M	21863	BOLT – round head, square neck, 3/8 NC x 3/4 inch		
N	30228	NUT – lock, smooth flange, 3/8 NC distorted thread		
P	21526	BOLT – hex head, 5/16 NC x 1-1/4 inch		
Q	18597	WASHER – flat, 11/32 inch I.D.		
R	21403	NUT – serrated flange lock, 5/16 NC		

742 Hay Conditioner R/H DRIVES

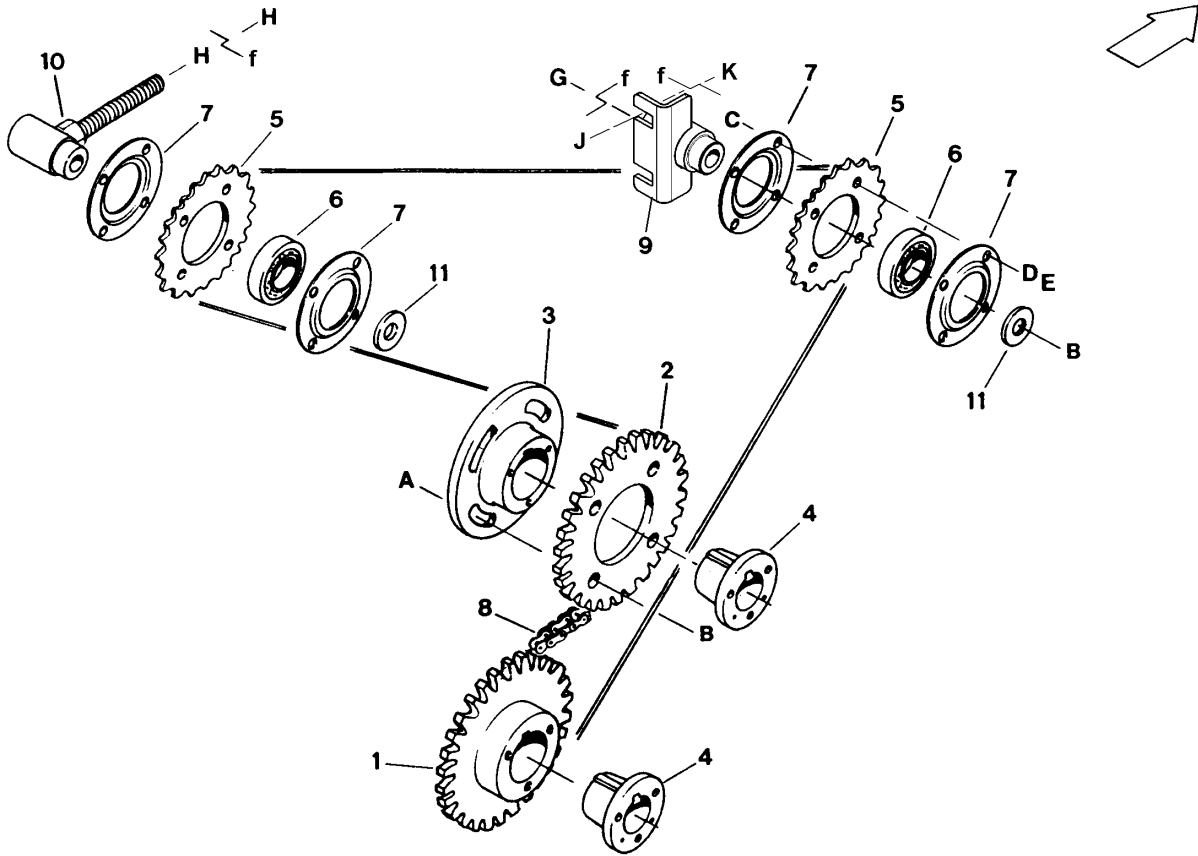

REF	PART NUMBER	DESCRIPTION	QTY	SERIAL NUMBER
1	28496	SPROCKET - lower roll	1	
2	47987	SPROCKET - upper roll	1	
3	47982	HUB - sprocket.....	1	
4	30256	BUSHING - split taper, with bolts & inner/outer key	2	
5	28482	SPROCKET - idler.....	2	
6	30090	BEARING - ball.....	2	
7	28491	RETAINER - bearing.....	4	
8	52116	CHAIN - roller, #60 x 104 links, endless.....	1	
9	125047	PIN - front idler, with support (was 52111, pin only).....	1	
10	52110	PIN - rear idler, with adjusting bolt.....	1	
11	22072	WASHER - flat	2	
A	18523	BOLT - round head, square neck, 5/8 NC x 1-1/2 inch		
B	18666	NUT - lock, 5/8 NC distorted thread		
C	21087	BOLT - hex head, 5/16 NC x 1 inch		
D	18636	WASHER - lock, 5/16 inch		
E	18589	NUT - hex, 5/16 NC		
G	21158	BOLT - round head, square neck, 5/8 NC x 4 inch		
H	18592	NUT - hex, 5/8 NC		
J	21868	BOLT - round head, short square neck, 1/2 NC x 1 inch		
K	50186	NUT - lock, smooth flange, 1/2 NC distorted thread		

~ f REF Indicates where hardware passes through frame member.

742 Hay Conditioner ROLL GAP & TENSION GROUP

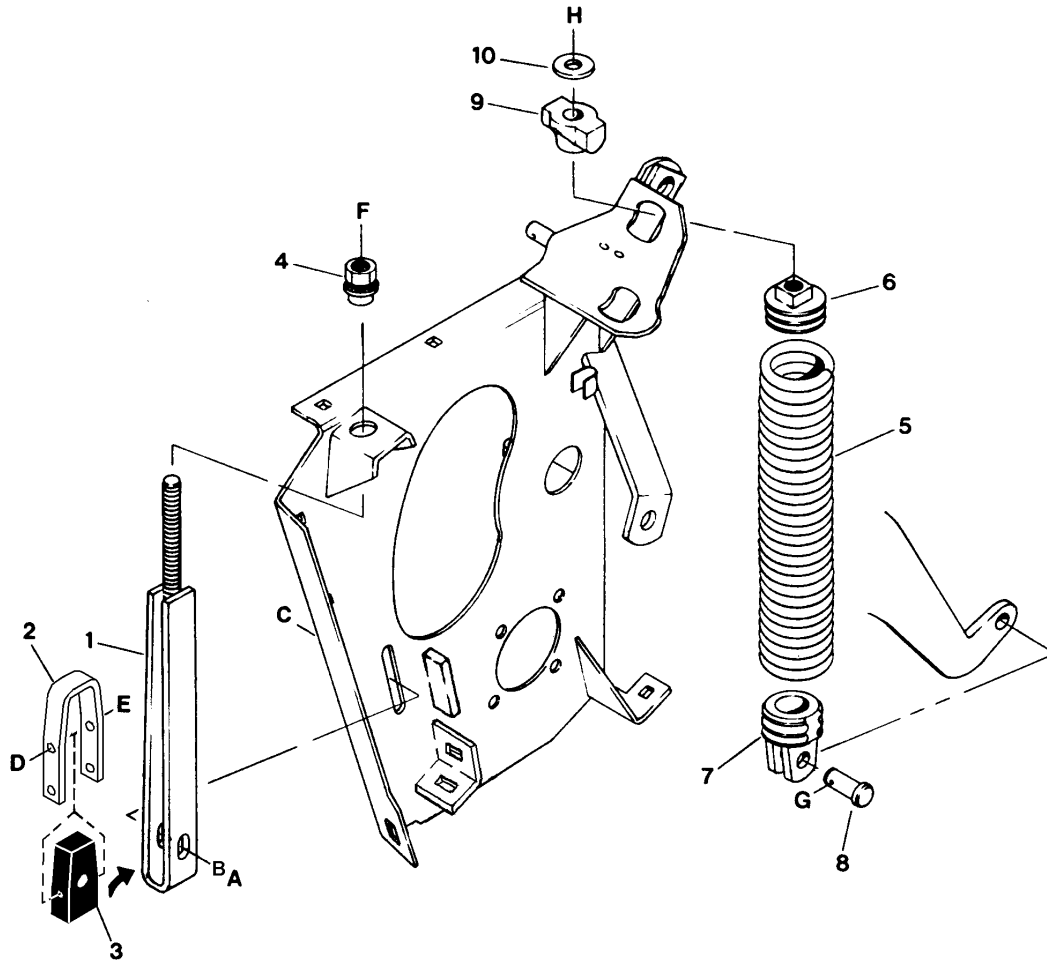

REF	PART NUMBER	DESCRIPTION	QTY	SERIAL NUMBER
1	52073	ROD - roll gap adjuster.....	2	
2	115763	CHANNEL – adjuster (see note 1)	2	
3	115764	PAD – rubber (see note 1)	2	
4	52140	TUBE - adjuster.....	2	
5	47048	SPRING - roll tension	2	
6	47922	INSERT - spring, with threaded hole.....	2	
7	47925	INSERT - spring, with clevis.....	2	
8	18619	PIN - clevis, 5/8 dia. x 1-3/16 effective length	2	
9	36011	PIVOT - spring.....	2	
10	22072	WASHER - flat	2	
A	30027	BOLT - round head, square neck, 1/2 NC x 2-1/4 inch		
B	18601	WASHER – flat, 13/16 inch ID		
C	50186	NUT – lock, smooth flange, 1/2 NC distorted thread		
D	21563	BOLT - hex head, 5/16 NC x 2-1/2 inch		
E	30280	NUT - lock, smooth flange, 5/16 NC distorted thread		
F	18592	NUT - hex, 5/8 NC		
G	18648	PIN - cotter, 3/16 x 1-1/4 inch		
H	21584	BOLT - hex head, 5/8 NC x 2-1/2 inch		

742 Hay Conditioner HEADER MOUNTING PARTS

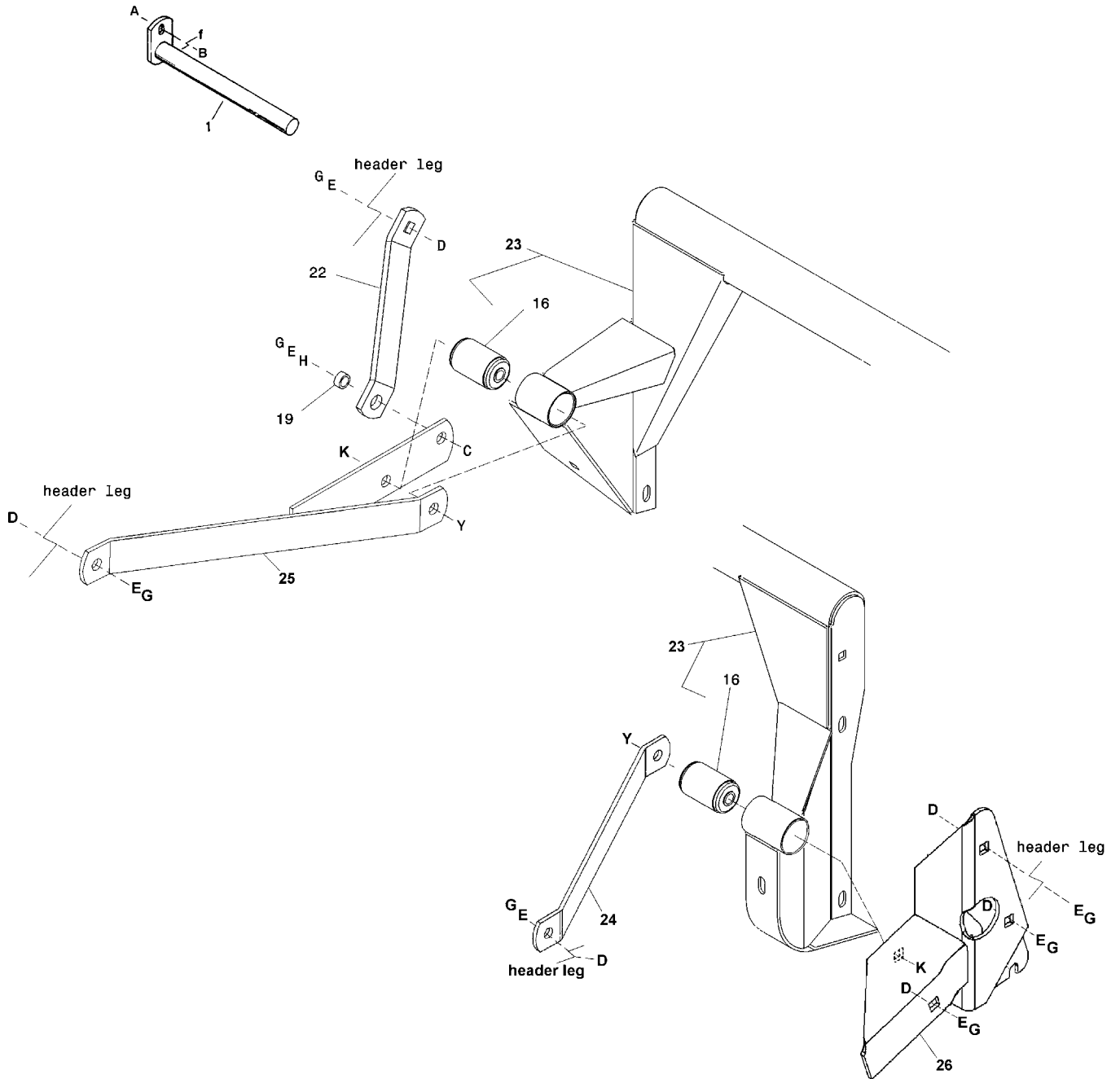

**742 Hay Conditioner
HEADER MOUNTING PARTS**

REF	PART NUMBER	DESCRIPTION	QTY	SERIAL NUMBER
1	52035	ROD - conditioner stop, mounts through header R/H leg	1	
16	21897	BUSHING – rubber.....	2	
19	102921	SPACER – tube.....	1	
22	115307	BAR - support, right.....	1	
23	115770	ADAPTER – mounting, includes 2 bushings (item 16).....	1	
24	115765	BAR – bushing support	1	
25	115805	SUPPORT – right	1	
26	115766	SUPPORT – left	1	
A	21863	BOLT – round head, short square neck, 3/8 NC x 3/4 inch		
B	30228	NUT – lock, smooth flange, 3/8 NC distorted thread		
C	21582	BOLT - hex head, 5/8 NC x 1-3/4 inch		
D	18523	BOLT - round head, square neck, 5/8 NC x 1-1/2 inch		
E	18639	WASHER - lock, 5/8 inch		
G	18592	NUT - hex, 5/8 NC		
H	18600	WASHER - flat, 21/32 inch I.D.		
K	50225	NUT – lock, smooth flange, 5/8 NC, distorted thread		
Y	21720	BOLT - hex head, 5/8 NC x 4-1/2 inch		
~ f	REF	Indicates where hardware passes through frame member.		

742 Hay Conditioner FLOAT GROUP

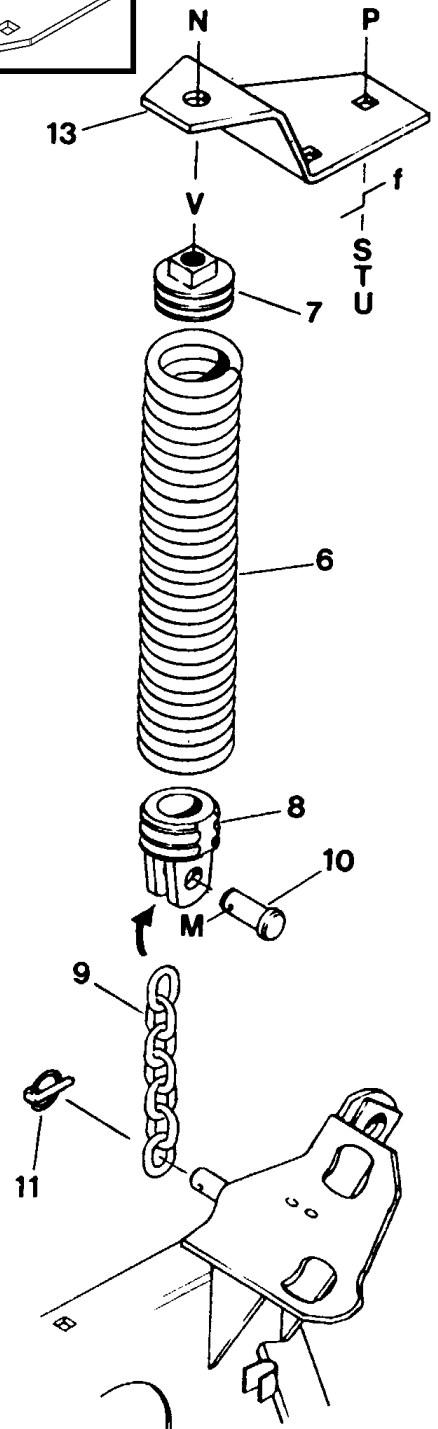
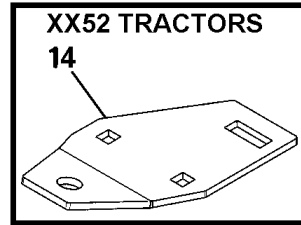
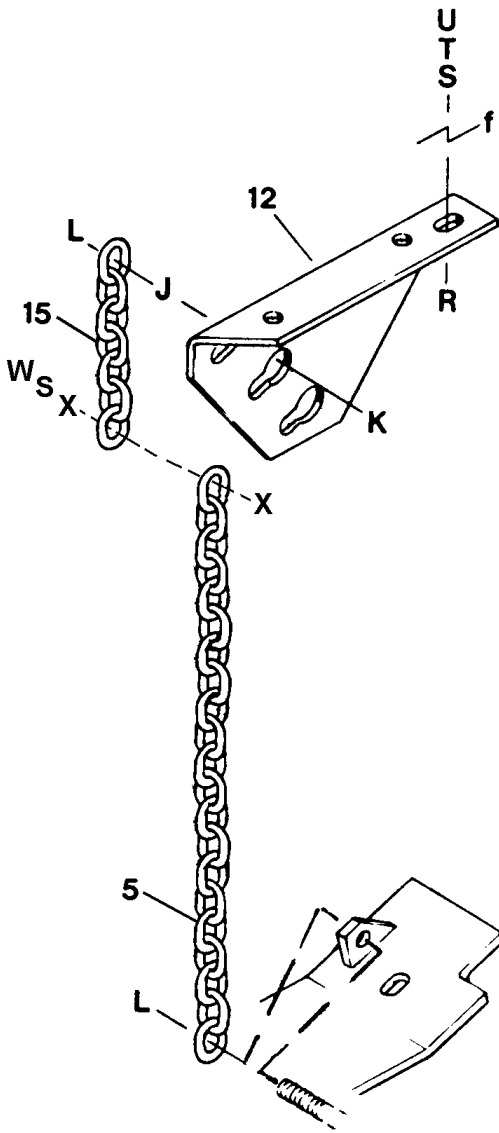

742 Hay Conditioner FLOAT GROUP

REF	PART NUMBER	DESCRIPTION	QTY	SERIAL NUMBER
5	47999	CHAIN - link, right.....	1	
6	47048	SPRING - conditioner float.....	1	
7	47922	INSERT - spring, with threaded hole.....	1	
8	47925	INSERT - spring, with clevis.....	1	
9	47981	CHAIN - link, left.....	1	
10	18619	PIN - clevis, 5/8 x 1 3/16 inch effective length.....	1	
11	50193	PIN - lynch.....	1	
12	52120	SUPPORT - right chain, mounts to tractor frame.....	1	
13	52121	● SUPPORT - float spring, mounts to tractor left floorboard.....	1	
14	115882	■ SUPPORT – float spring, mounts to tractor left floorboard.....	1	
15	115883	■ CHAIN – link, right, 195 mm extension.....	1	
J	18591	NUT - hex, 1/2 NC		
K	30515	BOLT - round head, square neck, 1/2 NC x 1-3/4 inch		
L	18697	NUT - lock, 1/2 NC distorted thread		
M	18648	PIN - cotter, 3/16 x 1-1/4 inch		
N	50080	BOLT - hex head, 5/8 NC x 4-1/2 inch, thread full length		
P	21471	BOLT - round head, square neck, 1/2 NC x 1-1/4 inch		
R	21491	BOLT - hex head, 1/2 NC x 1-1/4 inch		
S	18599	WASHER - flat, 17/32 inch I.D.		
T	18638	WASHER - lock, 1/2 inch		
U	18591	NUT - hex, 1/2 NC		
V	18592	NUT - hex, 5/8 NC		
W	21672	■ BOLT – hex head, 1/2 NC x 3 inch (for chain extension)		
X	50186	■ NUT – lock, smooth flange, 1/2 NC distorted thread		
~ f	REF	Indicates where hardware passes through frame member.		

<p>● - MacDon 9250/9350, Westward 9250/9350, Prairie Star 4940/4950, Premier 2940/2950, Harvest Pro 8140/8150</p> <p>■ - MacDon 9352, Westward 9352, Prairie Star 4952, Premier 2952, Harvest Pro 8152</p>
--

742 Hay Conditioner FORMING SHIELD GROUP

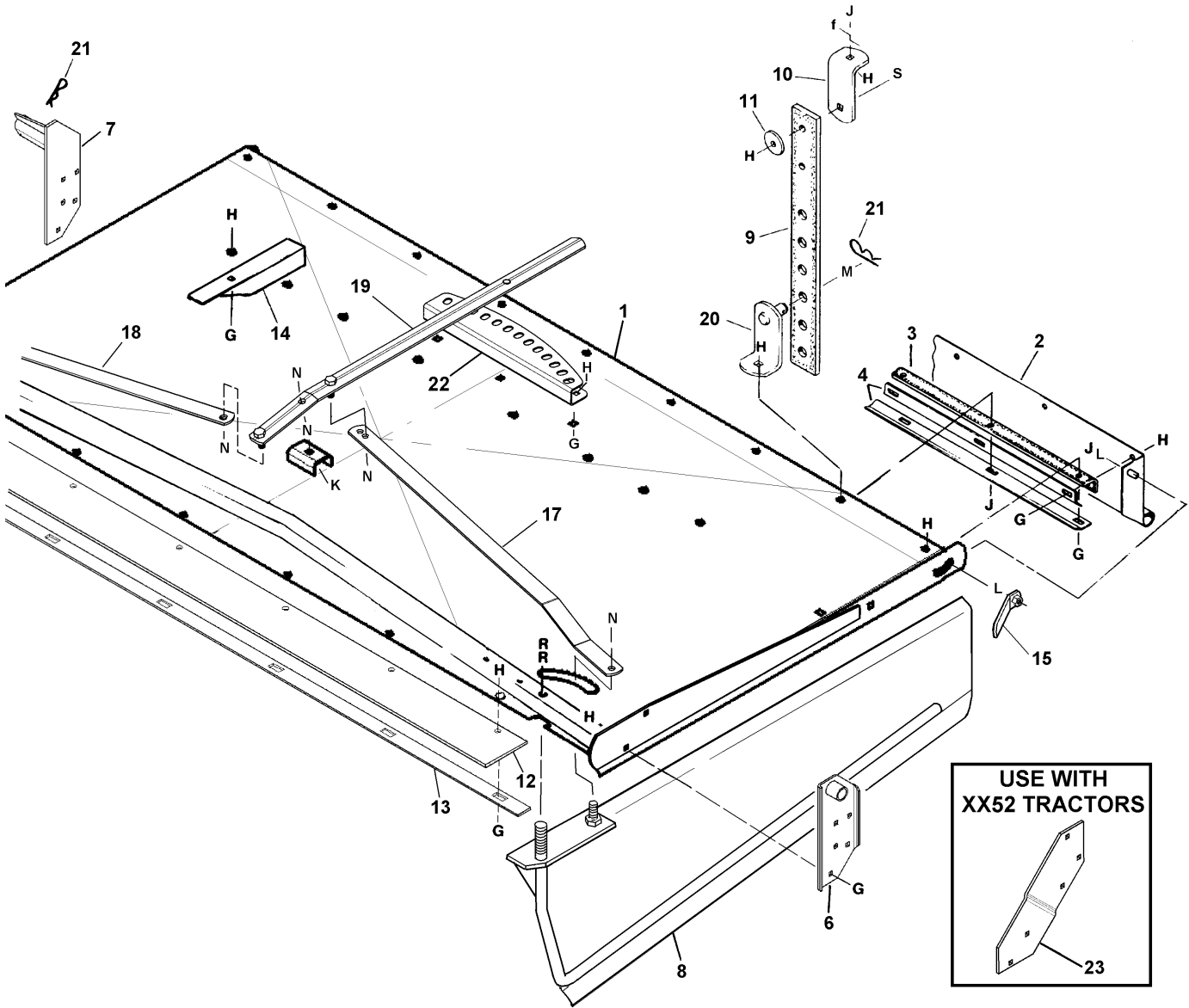

**742 Hay Conditioner
FORMING SHIELD GROUP**

REF	PART NUMBER	DESCRIPTION	QTY	SERIAL NUMBER
1	115311	COVER - top	1	
2	47576	DEFLECTOR - rear	1	
3	47578	HINGE - rubber, rear	1	
4	47577	STRAP - deflector hinge support.....	2	
6	130423	SUPPORT - mounting, LH (was 115800)	1	
7	130421	SUPPORT - mounting, RH (was 115801)	1	
8	115300	SHIELD - forming, left	1	
	115301	SHIELD - forming, right	1	
9	47996	STRAP - rubber, rear support	2	
10	47580	ANGLE - tractor mounting	2	
11	16652	WASHER - flat	2	
12	115842	STRIP - rubber	1	
13	115843	BAR - support for item 12.....	1	
14	47042	DEFLECTOR - fin (4 standard, 8 possible).....	4	
15	115651	HANDLE - rear deflector.....	2	
17	115294	LINK - L/H, side deflector	1	
18	115295	LINK, R/H, side deflector.....	1	
19	115926	HANDLE - side deflectors.....	1	
20	52154	ANGLE - lower, with pin.....	2	
21	13125	PIN - hair.....	3	
22	115920	SUPPORT - side deflector handle.....	1	
23	115979	PLATE - mounting (for use on 9352, 4952, 2952, 8152 tractor only)	2	
G	21863	BOLT - round head, square neck, 3/8 NC x 3/4 inch		
H	30228	NUT - lock, flange head, 3/8 NC distorted thread		
J	19965	BOLT - round head, square neck, 3/8 NC x 1 inch		
K	30027	BOLT - round head, square neck, 1/2 NC x 2-1/4 inch		
L	18599	WASHER - flat, 17/32 inch I.D.		
M	18600	WASHER - flat, 21/32 inch I.D.		
N	50186	NUT - lock, smooth flange, 1/2 NC distorted thread		
P	21478	BOLT - round head, square neck, 3/8 NC x 2-1/2 inch		
R	18592	NUT - hex, 5/8 NC		
S	19966	BOLT - round head, square neck, 3/8 NC x 1-1/4 inch		
~ f	REF	Hardware passes through frame member		

NUMERICAL LIST

<u>PART NO.</u>	<u>PAGE</u>	<u>PART NO.</u>	<u>PAGE</u>	<u>PART NO.</u>	<u>PAGE</u>	<u>PART NO.</u>	<u>PAGE</u>
11142	5	47994	5	130423	13		
13125	13	47996	13				
16652	13	47999	11				
18619	7	50182	3				
18619	11	50187	3				
21062	5	50188	3				
21301	5	50193	11				
21897	3	52035	9				
21897	9	52040	3				
21934	5	52073	7				
22072	5	52102	3				
22072	6	52110	6				
22072	7	52116	6				
28482	6	52117	3				
28491	6	52120	11				
28496	6	52121	11				
30031	3	52140	7				
30090	5	52154	13				
30090	6	52159	5				
30256	5	52161	5				
30256	6	101110	5				
30574	3	101173	3				
30576	3	102921	9				
36011	5	115294	13				
36011	7	115295	13				
47042	13	115300	13				
47048	5	115301	13				
47048	7	115307	9				
47048	11	115311	13				
47576	13	115651	13				
47577	13	115763	7				
47578	13	115764	7				
47580	13	115765	9				
47711	3	115766	9				
47712	3	115770	3				
47713	3	115770	9				
47713	3	115772	3				
47723	3	115805	9				
47724	3	115842	13				
47922	5	115843	13				
47922	7	115882	11				
47922	11	115883	11				
47925	5	115890	5				
47925	7	115892	5				
47925	11	115896	5				
47966	5	115920	13				
47969	5	115926	13				
47972	5	115976	3				
47976	5	115977	3				
47977	5	115979	13				
47978	5	125047	6				
47981	11	125049	3				
47982	6	125050	3				
47987	6	130421	13				

MODEL 742 SUGGESTED STOCKING LIST

P.C. REF	PART NUMBER	DESCRIPTION	SUGGESTED QTY.		ORDER QTY	UNIT PRICE	EXT. PRICE
			2 UNITS	5 UNITS			
<u>FRAME, ROLLS & ROLL ARMS - Parts Catalog Pg. 3</u>							
7	30574	BUSHING - rubber	0	1			
11	30031	BEARING - with lock collar	2	4			
12	30576	FLANGE - bearing, inner	0	1			
13	50182	FLANGE - bearing	0	1			
19	52102	SHOE - left	1	2			
20	52117	SHOE - right	0	1			
<u>L/H DRIVES - Parts Catalog Pg. 5</u>							
6	30090	BEARING - ball	0	2			
20	47994 *	BELT - matched set of three - 942	1	2			
	101110 *	BELT - matched set of three - 972	1	2			
<u>R/H DRIVES - Parts Catalog Pg. 6</u>							
1	28496	SPROCKET - lower roll	0	1			
2	47987	SPROCKET - upper roll	0	1			
5	28482	SPROCKET - idler	0	2			
8	52116	CHAIN - roller	1	2			

* - Order to suit header type.